

Using a LaBr₃:Ce scintillator for positron annihilation lifetime spectroscopy^{*}

LIU Jun-Hui(刘军辉)^{1,2,3} LI Dao-Wu(李道武)^{1,2} ZHANG Zhi-Ming(章志明)^{1,2}
 WANG Bao-Yi(王宝义)^{1,2} ZHANG Tian-Bao(张天保)^{1,2}
 HAO Jia(郝佳)⁴ WEI Long(魏龙)^{1,2;1)}

¹ Key Laboratory of Nuclear Analysis Techniques, Institute of High Energy Physics,
 Chinese Academy of Sciences, Beijing 100049, China

² Beijing Engineering Research Center of Radiographic Techniques and Equipment, Beijing 100049, China

³ Number 8, Qinghe Building, Beijing 100085, China

⁴ Beijing Huakailong Electronics Co. Ltd, Beijing 100085, China

Abstract: A LaBr₃:Ce scintillator has a high light output (~ 60000 p.e/MeV) and a short decay constant (< 25 ns), which makes it good for time spectrometry. Compared with a BaF₂ scintillator, it can bear a much higher count rate, and can be coupled to photomultipliers without using a quartz window. In this work, a positron annihilation lifetime spectrometer (PALS) consisting of two bulks of $\phi 25$ mm \times 25 mm LaBr₃:Ce scintillator coupled to two XP20D0 photomultipliers, respectively, was built. A time resolution of FWHM=206 ps was measured for the PALS with a ⁶⁰Co source at the energy window for ²²Na. With this spectrometer, a reasonable lifetime value $\tau=221\pm 4$ ps in a pure Si sample is obtained, which means that the utilization of LaBr₃:Ce as the detector for a PALS is feasible.

Key words: PALS, LaBr₃:Ce

PACS: 29.40.Mc **DOI:** 10.1088/1674-1137/36/4/016

1 Introduction

Plastic scintillators and BaF₂ scintillators have been widely used in positron annihilation lifetime spectrometers for many years due to their good time resolution [1–5]. It is well known that the detection efficiency of plastic spectrometers is quite low due to their very low stopping power. As for BaF₂ scintillators, a fast photomultiplier with a quartz window is needed due to the scintillant light at 220 nm of its short component. In addition, the count rate of a BaF₂ detector can not be very high because of its slow component, whose decay constant is 620 ns. Furthermore, in our experience, it seems that the BaF₂ crystal can be eroded slowly by the coupled silicon oil, which would degrade the time resolution of the system slowly but continuously. So, it is worthwhile searching for new scintillators for use in a PALS. For example, GAO Xin [6] studied the use of

a LaCl₃:Ce scintillator for a PALS, and M. Haaks [7] tested an LSO scintillator for a PALS.

LaBr₃:Ce is a new scintillator developed in recent years. Its light output of ~ 60000 photons/MeV [8] is higher than that of LaCl₃:Ce or LSO and the decay constant < 25 ns [7], is faster than that of the latter ones, which means that LaBr₃:Ce would be a good candidate for a PALS.

As a comparison, the scintillation yield and the decay time spectra of a LaBr₃:Ce crystal we obtained was tested with the single photon method [8]. Using LaBr₃ crystals, a PALS was built at our Lab. The system performance of the spectrometer has been tested correctly.

2 The measurement of the properties of the LaBr₃:Ce scintillator

The two bulks of $\phi 25$ mm \times 25 mm LaBr₃:Ce

Received 7 June 2011, Revised 14 November 2011

^{*} Supported by National Natural Science Foundation of China (10805049, 10775149)

1) E-mail: weil@ihep.ac.cn

©2012 Chinese Physical Society and the Institute of High Energy Physics of the Chinese Academy of Sciences and the Institute of Modern Physics of the Chinese Academy of Sciences and IOP Publishing Ltd



Fig. 1. The $\phi 25 \text{ mm} \times 25 \text{ mm}$ LaBr₃:Ce scintillator.

scintillator, shown in Fig. 1, were provided by Beijing Huakailong Electronics Co. Ltd. Coupled to a XP20D0 PMT, whose sensitivity for blue light is $11.1 \mu\text{A}/1 \text{ mf}$, with silicon oil, their energy resolution for 662 keV photons was FWHM 3.2% and 3.4%, respectively. Their light output was measured by using the single photon method [9]. The single photon electron spectrum of the PMT is shown in Fig. 2. The GSO crystal and ²⁴¹Am were used to work out the

gain. Dropping the PMT H.V. from 1400 V to 800 V, and comparing the barycenter of the spectrum with the peak value listed in Table 1, the light output of the two LaBr₃:Ce crystals were averagely calculated as 15800 p.e./MeV for a 511 keV gamma ray.

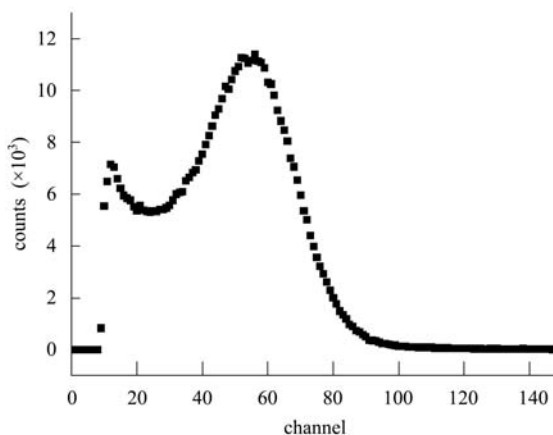

Fig. 2. The single photon electron spectrum of XP20D0.

Table 1. The energy spectrum under different conditions.

	energy/keV	H.V./V	Pre-AmpOtec113	Otec572 amplificatory	shaping time/ μs	peak value	photon electrons
single-photon source	—	1400	with	500	0.5	54.24	1
GSO	59.54 (²⁴¹ Am)	1400	with	50	0.5	439.20	—
GSO	59.54 (²⁴¹ Am)	800	with	1000	0.5	280.35	—
the first $\phi 25 \text{ m} \times 25 \text{ mm}$ LaBr ₃ :Ce	511 (²² Na)	800	with	20	0.5	587.07	8477
the second $\phi 25 \text{ m} \times 25 \text{ mm}$ LaBr ₃ :Ce	511 (²² Na)	800	with	20	0.5	538.56	7776

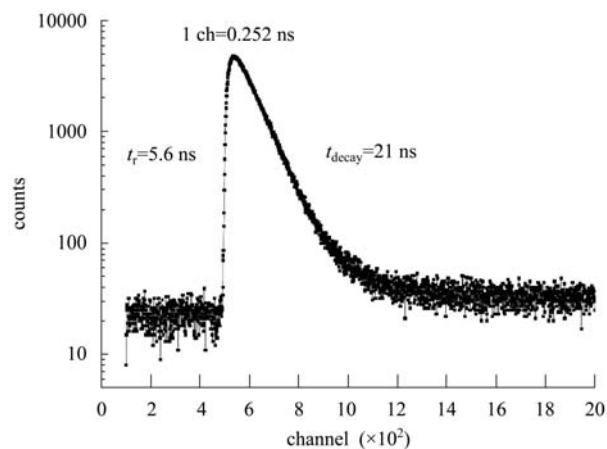

Fig. 3. The decay time spectra of the LaBr₃:Ce crystal.

The decay time spectra of the LaBr₃:Ce scintillator presented in Fig. 3 was also measured by using

the single photon method [9]. The calculated rise time of the pulse for 10%–90% was 5.6 ns, and the decay constant was 21 ns.

3 The composition of the PALS

As presented in Fig. 4, a PALS of fast-slow-coincidence system was built with the LaBr₃:Ce—XP20D0 detectors. This system is the same as the one described by Li Dao-Wu and Liu Jun-Hui except for the detectors [10]. The timing signal is drawn from the last dynode and the energy signal is obtained from the anode of the PMTs. The fast electronics, which is used to acquire the time spectrum of the positron annihilation events, includes two self-made signal inverters, a quad CFD Ortec935, a TAC Ortec567 and a MCA. The slow part, which is used to define the

energy windows for the start detector and the stop detector, consists of two amplifiers Otec572, two timing SCA Ortec552s and a self-made coincidence circuit. In addition, both of the coincidence gates of the start and stop channels on Ortec567 are used to limit random events.

A positron source ($20 \mu\text{Ci}$ of ^{22}Na), supported by two thin Kapton films, was mounted between two bulks of high pure Si in sandwich geometry. The start detector was placed perpendicular to the stop detector to avoid the coincidence of the two 511 keV γ -ray of positron annihilation.

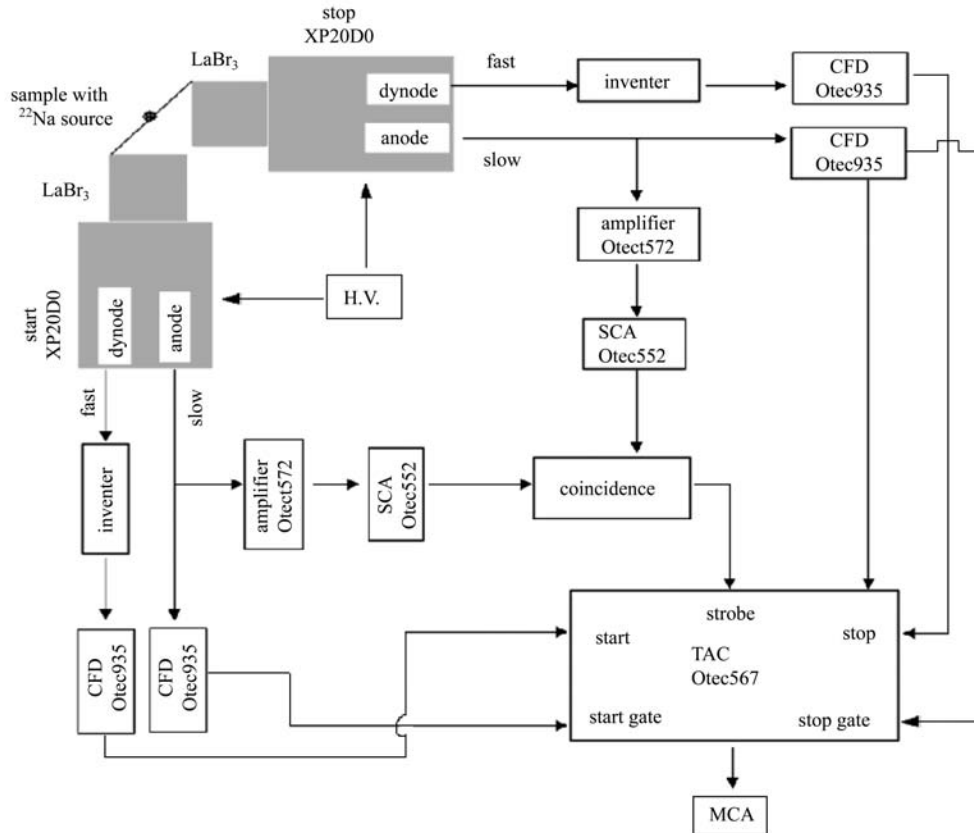

Fig. 4. A PALS of $\text{LaBr}_3\text{:Ce}$ scintillators.

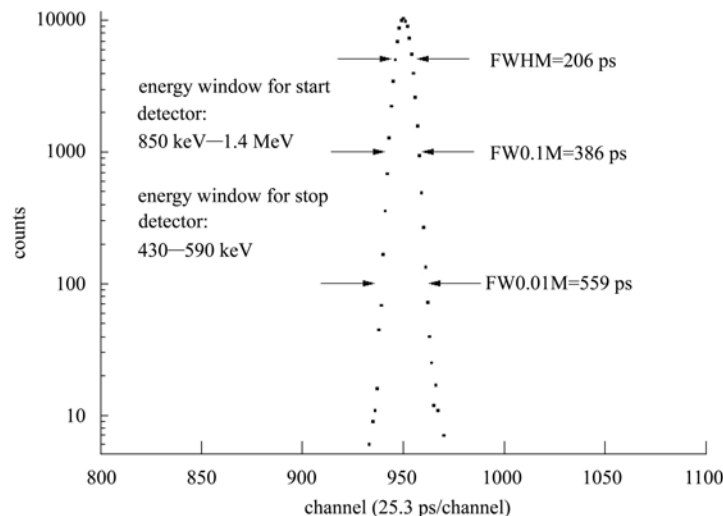

Fig. 5. The coincidence time resolution for the PALS. (FW0.1M means full width at 1/10 maximum, FW0.01M means full width at 1/100 maximum).

4 The PALS test

A 1 μCi ^{60}Co source was used to test the coincidence time resolution of the PALS, and a FWHM of 206 ps was obtained with the energy window set for ^{22}Na (850–1400 keV for the start detector and 430–590 MeV for the stop detector), shown in Fig. 5. The energy window for 511 keV γ -ray was set a little wider than the detected peak to get a higher count

rate because the ^{60}Co source is too weak.

As shown in Fig. 6, a PAL spectrum of the Si sample was obtained with the above system. The spectrum was analyzed by using the LT program version 9 [11]. Subtracting the contribution of the positrons annihilating in the source ($\sim 12\%$, 382 ps, Kpaton lifetime [12]), and on the sample surface ($\sim 0.3\%$, 1.3 ns), 221 \pm 4 ps was obtained for the lifetime in the Si bulks.

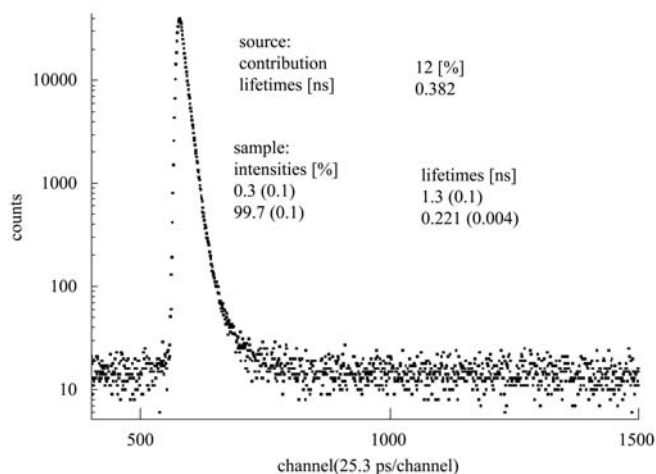

Fig. 6. The measured PAL spectrum.

5 Discussion

The measured lifetime in the Si sample was in agreement with the well known lifetime of positron annihilation in defect-free Si (220 ps) [13]. It is shown that a PALS of LaBr₃:Ce scintillator is feasible. The time resolution of the PALS is 206 ps, a little bigger than that of normal PALS of BaF₂ scintillators, which is good enough for most applications.

The decay constant of the light pulse of the LaBr₃:Ce scintillator we used is 21 ns, and its photo-

electron number is 15800 p.e/MeV, about 63000 photons/MeV converted into light output (PMT Q.E is about 25%). Both of them agree with the reported data [8]. Its rise time (5.6 ns), an important factor limiting the time resolution of the PALS [14], is related to the concentration of Ce ions in the LaBr₃ scintillator [8], the size of the crystal, and the encapsulation of the crystal [15]. With improvement in the technology of manufacture and encapsulation, the PALS of LaBr₃:Ce scintillators with better performance would be possible.

References

- Bauer W, Major J, Weiler W, Maier K, Schaefer H E. in: Positron Annihilation, Proc. of ICPA-7. Eds Jain P C, Singru R M, Gopinathan K P. Singapore: World Scientific, 1985. 804
- CHANG T et al. Nuclear Instruments and Methods in Physics Research Section A, 1987, **256**(2): 398–400
- WEI Z Y et al. Nuclear Instruments and Methods in Physics Research Section B, 1991, **61**(1): 61–66
- Cízek B F J et al. Nuclear Instruments and Methods in Physics Research Section A, 2000, **443**(2–3): 557–577
- WEI Long et al. Materials Science Forum, 2004, 445–446, 516
- GAO Xin et al. Nuclear Electronics & Detection Technology, 2007, **27**(2): 243–249 (in Chinese)
- Haaks M et al. Phys. Stat. Sol.(c), 2007, **4**(10): 4036–4039
- Moses W, Shah K. Nuclear Instruments and Methods in Physics Research Section A, 2005, **537**(1–2): 317–320
- CHANG Tian-Bao et al. HEP & NP, 1983, **7**(6): 674–680 (in Chinese)
- LI Dao-Wu et al. Chinese Physics C (HEP & NP), 2011, **35**(1): 100–103
- Kansy J. Nucl Instrum Methods A, 1996, **374**: 235–244
- Brusa R S et al. Applied Physics A, 1992, **54**(3): 233–238
- Dedoussis L T S et al. Journal of Radioanalytical and Nuclear Chemistry, 1996, **211**(1): 181–185
- Szczesniak T et al. Nuclear Science, IEEE Transactions on, 2009, **56**(1): 173–181
- Moses W W, Derenzo S E. Nuclear Science, IEEE Transactions on, 1999, **46**(3): 474–478