

Application of wavelet-based active power filter in accelerator magnet power supply

GUO Xiao-Ling(郭晓玲)¹⁾ CHENG Jian(程健)²⁾

Institute of High Energy Physics, Chinese Academy of Sciences, Beijing 100049, China

Abstract: Since modern accelerators demand excellent stability to magnet power supply (PS), it is necessary to decrease harmonic currents passing magnets. Aiming at depressing the rattle current from the PS in the Beijing electron-positron collider II, a wavelet-based active power filter (APF) is proposed in this paper. An APF is an effective device to improve the quality of currents. As a countermeasure to these harmonic currents, the APF circuit generates a harmonic current, countervailing harmonic current from PS. An active power filter based on wavelet transformation is proposed. Discrete wavelet transformation is used to analyze the harmonic components in the supply current, and an active power filter circuit works according to the analysis results. Our simulation and experiment results are given to prove the effect of the APF.

Key words: active power filter, high-precision direct current sources, harmonic current, wavelet analysis, Mallat, magnet power supply

PACS: 84.30.Vn, 07.50.Hp **DOI:** 10.1088/1674-1137/38/11/117007

1 Introduction

Most magnet power supplies of the accelerator in BEPC II are high-precision direct current sources. The quality of the current is one of the most important factors affecting the stability of beam orbit and, therefore, how to eliminate current harmonics is a popular topic in the power supply field.

Using an LC passive filter to decrease the rattle current is a common method to improve the PS's quality. Installing an active power filter (APF) is another way to do this. Usually, the cost of the first scheme is very high, although it can evidently reduce the harmonic current. Furthermore, as the supply's power increases, the size of filter increases, and its cost becomes much higher. The second APF method has an advantage of low cost [1].

Figure 1 presents a principle diagram of an APF. The APF is composed of two parts, which are an arithmetic logical unit (ALU) and a compensation circuit. Between them, the ALU circuit is able to detect the rattle current from the PS to get the information of harmonics, and the compensation circuit is used to generate a compensating current with the same value but in the opposite direction, thereby offsetting the harmonic from the PS [1].

It is beyond any doubt that an APF can eliminate an harmonic current. However, it is difficult to get the values of the harmonic's amplitude and phase, causing difficulty for the control of the APF circuit. This is one

of the main reasons for limiting the development and application of APF technology. A wavelet decomposition algorithm provides a new approach to this harmonic analysis.

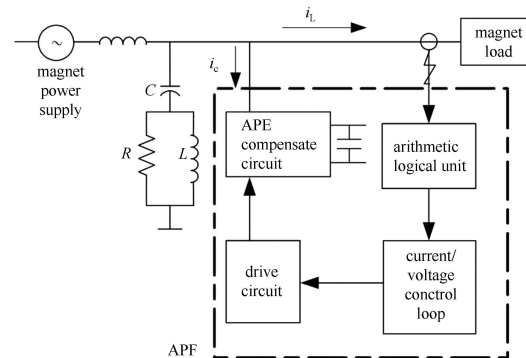

Fig. 1. Principle diagram of APF.

2 Wavelet analysis

Wavelet analysis is considered to be a breakthrough of Fourier analysis. It provides an adjustable window between time and frequency. The window becomes automatically narrow when observing the high-frequency signals, and it widens when focusing the low-frequency signals; namely, it has the characteristics of zoom in, which make it very suitable for harmonic analysis. The following section will introduce wavelet analysis [1, 2].

Received 20 December 2013

1) E-mail: guoxl@ihep.ac.cn

2) E-mail: chengj@mail.ihep.ac.cn

©2014 Chinese Physical Society and the Institute of High Energy Physics of the Chinese Academy of Sciences and the Institute of Modern Physics of the Chinese Academy of Sciences and IOP Publishing Ltd

If $\psi \in L^2(R)$ satisfies the admissibility condition of $\int \psi(t)dt = 0$, then ψ can be used as a mother wavelet function, and then the continuous wavelet transformation (CWT) to signal $x(t)$ can be defined as Eq. (1).

$$\begin{aligned} \text{WT}_x(a,b) &= a^{\frac{1}{2}} \int_{-\infty}^{\infty} x(t) \bar{\psi} \left(\frac{t-b}{a} \right) dt \\ &= \langle x(t), \psi_{a,b}(t) \rangle. \end{aligned} \quad (1)$$

Where $a, b \in R$, $a > 0$ is the scaling parameter, and b is the corresponding shifting parameter, and $\psi_{(a,b)}(t)$ is the scaling and shifting of $\psi(t)$.

Discrete wavelet transformation (DWT) makes it possible to realize WT in digital processing. It divides the original signal into separate frequency bands, so it is possible to analyze higher frequency components for each band independently. The input at each stage is always split into two bands, and then the higher band becomes one of the outputs, while the lower band is further split into two bands. This procedure is continued until a desire resolution is achieved, from which the recursion Equations of decomposing coefficient are shown as follows:

$$a_{j+1}(k) = \sum_m h_0(m-2k) a_j(m), \quad (2)$$

$$d_{j+1}(k) = \sum_m h_1(m-2k) a_j(m). \quad (3)$$

Where $h_0(k)$ refers to unit sampling response of low-pass digital filter, and $h_1(k)$ refers to unit sampling response of the high-pass digital filter, respectively, and a_j and d_j are the detail parts and the approaching parts of the analysis results. By making j increase from 0 gradually, the signals in different bandwidths can be obtained, as shown in Fig. 2.

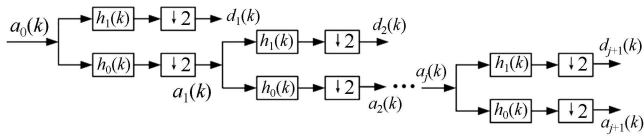

Fig. 2. Process of decomposing using wavelet analysis.

The data can be decomposed to accommodate the process shown in Fig. 2, but the decomposed result data cannot directly display the ripple current, which needs to be reconstructed as shown in Fig. 3.

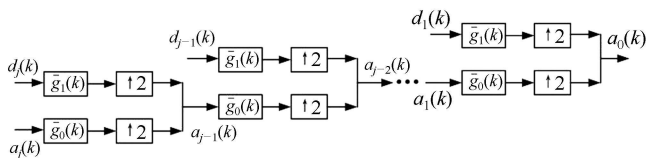

Fig. 3. Process of wavelet reconstructing.

3 Wavelet-based harmonic analysis

Since the ripple currents from parts of BEPC II's magnet power supplies are not minute enough, a wavelet-based APF is designed based on the mentioned theory.

The APF referred to above adopts a full bridge inverter circuit as its main circuit, and it analyzes the sampled data using wavelet transformation. The circuit uses the classic PI control in its current loop, which is common in a power supply, so it is not described in this article. However, harmonic analysis is an important part in APF technology, and using a wavelet is a novelty, so it will be discussed in detail below.

3.1 Sampling frequency

As the load varies, the concerned bandwidth differs. The bandwidth cared about is called interesting-bandwidth. We set the sampling frequency to f_{sample} , and the sampled data to $x(n)$, according to the Whittaker-Shannon sampling theorem, the bandwidth of $x(n)$ is then $f_{\text{sample}}/2$. Obviously, the sampling frequency should be at least two times the interesting-bandwidth. To reduce the amount of calculation, we make the sampling frequency to be two times the interesting-bandwidth, so that the bandwidth of $x(n)$ is exactly the interesting-bandwidth. For the accelerator magnet power supply, the harmonics below 1000 Hz need to be reduced, so it is appropriate to set the sampling rate to 2048 Hz.

3.2 Wavelet function

The selection of mother wavelets is not only a practical difficulty, but also a key point because there is no standard or reference and it will directly affect the results of the analysis. Matlab provides an effective way to choose the mother wavelet, which is a simulation. The Db5 wavelet basis function is selected to be the mother wavelet, according to the simulation result, but the simulation results are not shown in this paper due to the limitations of space.

3.3 Delay and real-time computation

The calculations of our analysis demands a certain amount of sampled data, which causes a delay to the harmonics counteraction because the system has to wait until the quantity of sampled data meets the calculation's needs. In this paper, the sampling rate is 2048 Hz, and the sampling should last at least two periods of lowest interesting-bandwidth, which is 50 Hz in this paper. Along with the increase in the analysis layer, the amount of required data also increases. In order to realize five layer analyses, the sample time is at least 10 times the cycle of 50 Hz, which is 20 ms. To make sure that the calculation result is precise, in this paper the sample time

Table 1. Coefficients of the DB5 wavelet function.

$h_0(0\ 9)$	$h_1(0\ 9)$	$g_0(0\ 9)$	$g_1(0\ 9)$
0.00235871396953395	-0.113209491291779	0.2264189825835584	0.00471742793906790
-0.00889593505097710	0.426971771352514	0.8539435427050283	0.0177918701019542
-0.00441340005417915	-0.512163472129598	1.0243269442591967	-0.00882680010835830
0.054851329321067	0.0978834806739039	0.1957669613478078	-0.109702658642134
-0.0228005659417735	0.171328357691468	-0.3426567153829353	-0.0456011318835469
-0.171328357691468	-0.0228005659417735	-0.0456011318835469	0.342656715382935
0.0978834806739039	-0.0548513293210670	0.1097026586421339	0.195766961347808
0.512163472129598	-0.00441340005417915	-0.0088268001083583	-1.02432694425920
0.426971771352514	0.00889593505097710	-0.0177918701019542	0.853943542705028
0.113209491291779	0.00235871396953395	0.0047174279390679	-0.226418982583558

value is taken as 1 second. With the aim of achieving real-time analysis, we update the data after each sampling. We use the latest sampled data as $x(2047)$, and take $x(n)$, which are used in last calculation as $x(n-1)$ in current analysis, and the oldest data $x(0)$ is discarded. By this process of updating the data, a real-time harmonic analysis is implemented. However, the delay of the APF starting work is inevitable because the calculation needs to wait until 2048 data have been sampled.

3.4 Calculations

Given that the sample-rate and mother-wavelet are determined, the current data can be analyzed. For the db5 wavelet function, the coefficients are shown in Table 1 [3].

We set $a_0 = x(n)$, then the data can be analysed according to Eqs. (2) and (3). Each decomposition divides the data bandwidth into two parts averagely, so the DC value is distinguished from the original data after five times of analysis.

3.5 Key condition of actualizing

The four parts described in the anterior sections are keys of the wavelet-based APF's application in accelerator power supply. In addition, another important factor is how to accomplish wavelet calculation in digital control processing.

For a long time, a factor limiting the application of wavelet in the power supply field was the large amount of calculation. To solve this problem, a Field-Programmable Gate Array (FPGA) has been used for wavelet calculation. One important characteristic of the FPGA is that parallel computing can be realized in FPGA, which makes real-time calculation feasible.

4 Control of wavelet-based APF

Currently, the common APF is involved in the control loop of power supply. In this paper, the wavelet-based APF is independent of the power supply's control system, which can be regarded as an independent power supply.

Since it is independent of the magnet power supply, it can be installed or removed expediently. When the quality of the power supply cannot meet the accelerator's desire because it is aging, this APF can be installed and is able to improve the current stability. Given that the accelerator is already built and running but needs to be upgraded, this APF can be used to improve the performance of the power supply.

In the control part of this APF, the wavelet analysis is taken as the reference of PI controller, and the APF's output current is taken as the feedback value.

5 Simulation and experiment

To demonstrate the validity of this wavelet analysis and the effect of this APF, the work process of the mentioned APF is simulated by using Matlab software. The experiment results are also shown to verify the Matlab simulation results.

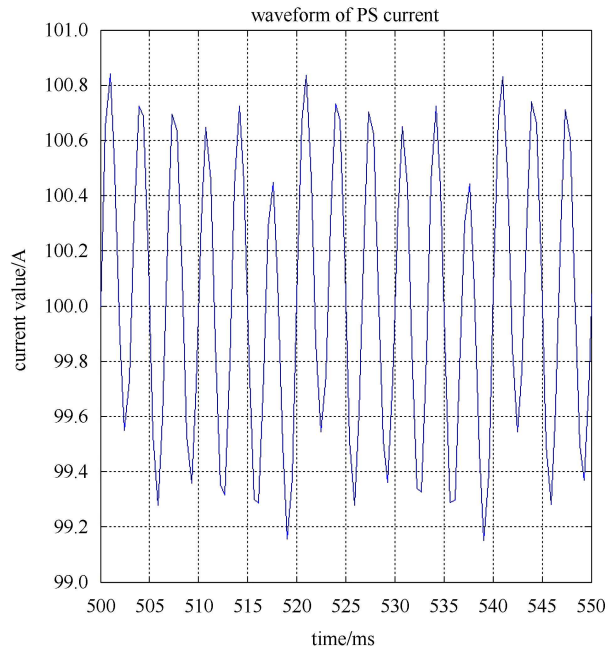

Fig. 4. Current waveform of PS.

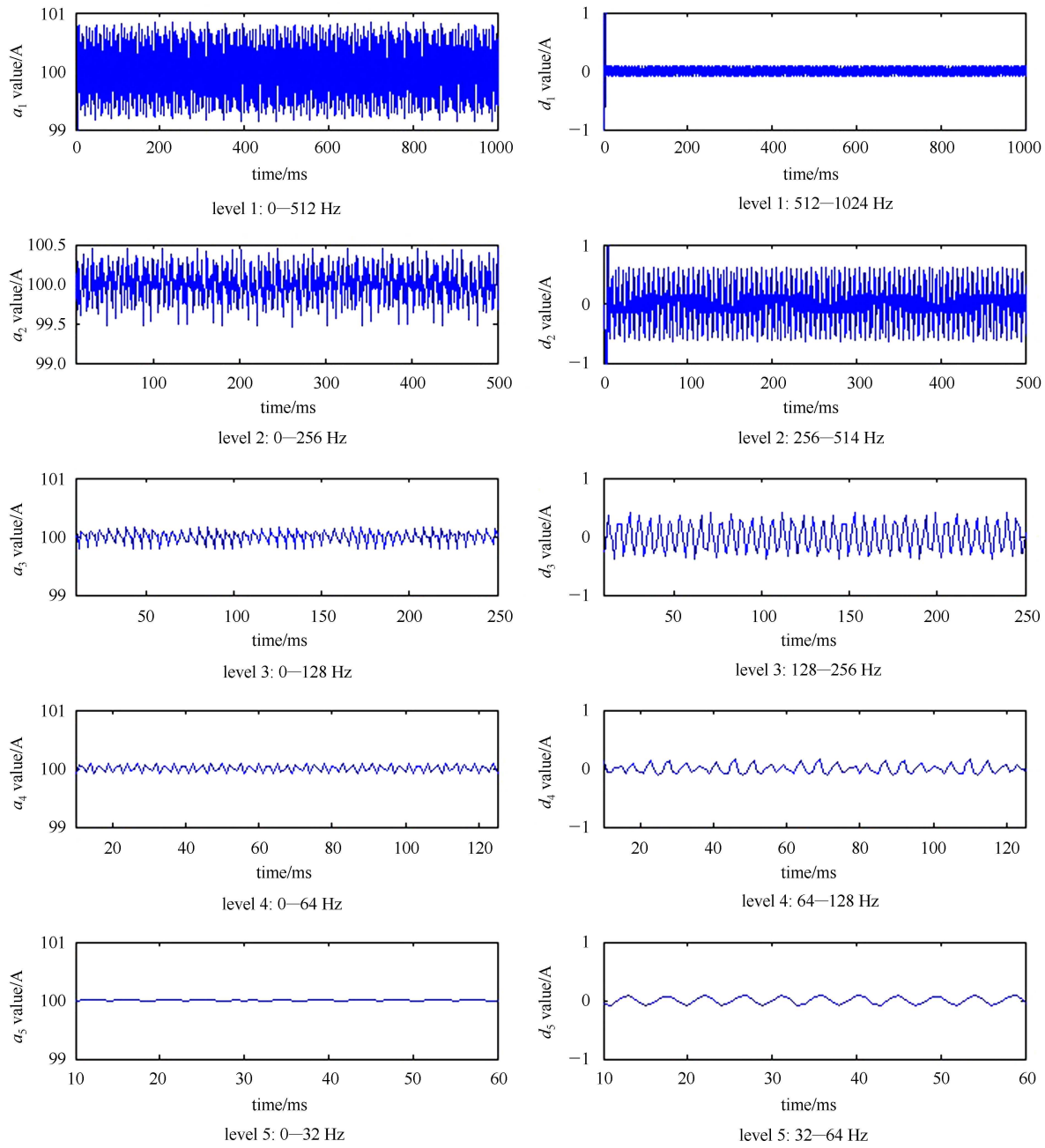

Fig. 5. Waveform of wavelet-decomposition process simulation.

5.1 Matlab simulation

Most accelerator magnet power supplies outputs dc, so the simulation is modeled on a three-phase bridge rectifier of stabilized current supply. We set the outputted dc current (I_{p-p}) to 100 A, and the harmonics' amplitude of 50 Hz, 100 Hz, 150 Hz and 300 Hz are, respectively, 10 mA, 10 mA, 10 mA and 70 mA, which is shown in Fig. 4.

The obtained spectrum bandwidth and waveform

after decomposition are shown in Fig. 5, in which a_j denotes low frequency signals while d_j shows the high frequency ones.

We reconstruct the harmonics within 1024 Hz into a signal named harmonic-refactoring component, and then control the APF circuit to output current with same amplitude but in the opposite direction, the outputted current is shown in Fig. 6. After installing this APF to the magnet, the current through the magnet is optimized, as displayed in Fig. 7.

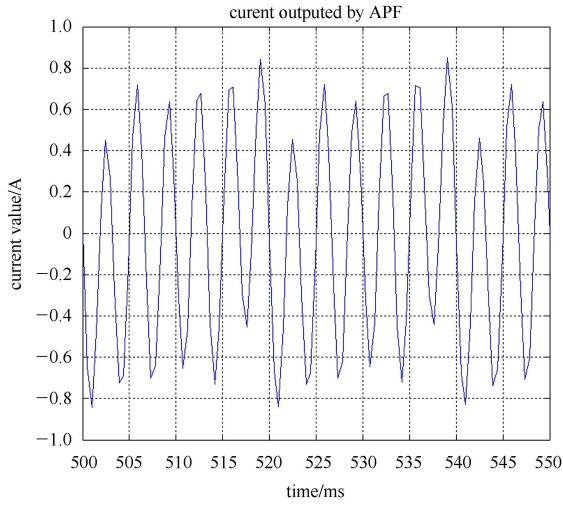

Fig. 6. Current waveform of APF circuit.

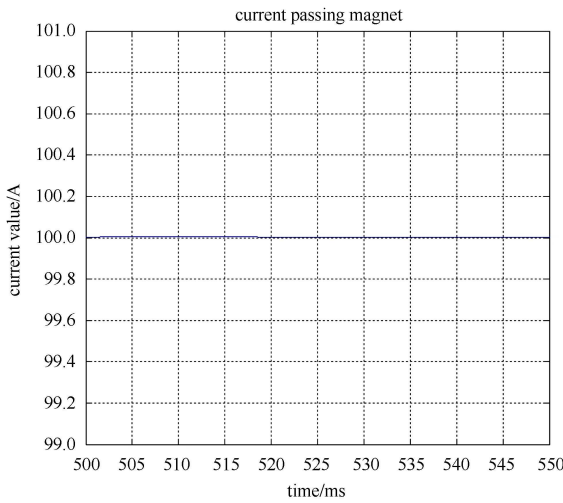

Fig. 7. Final current waveform through load.

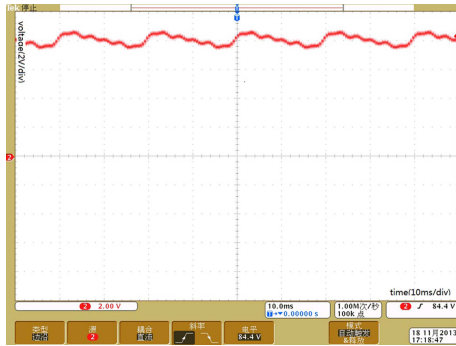

Fig. 8. Waveform of PS output voltage.

5.2 Prototype experiment

The experiment is conducted on a 5 A prototype PS, whose voltage is 10 V. since the current waveform is hardly displayed by oscilloscope, a resistance is chosen as load, so that the status of the voltage is exactly the same with the current. The power supply's output voltage is displayed in Fig. 8, and Fig. 9 shows the output voltage of the APF.

The power supply and APF connect the resistance in parallel, and the final waveform of voltage across load is shown in Fig. 10.

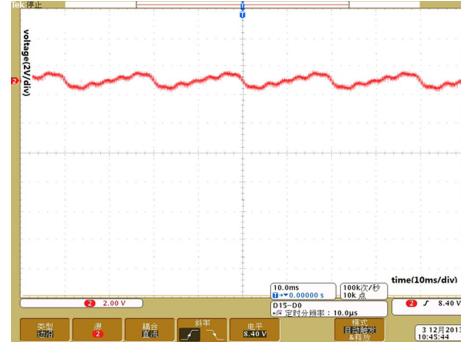

Fig. 9. Waveform of APF output voltage.

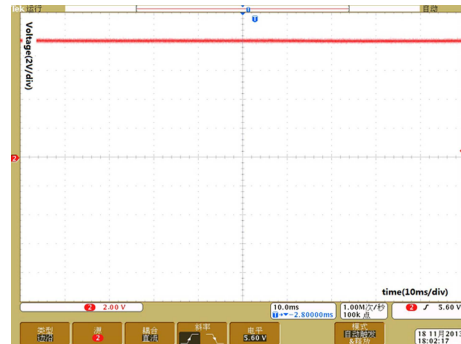

Fig. 10. Waveform of voltage across the resistance.

6 Conclusion

The wavelet-based APF mentioned in this paper can effectively decrease the rappel current. By using wavelet analysis, the APF aimed bandwidth can be selected and modified easily. The simulation reveals its work process, and the experiment result approves the description in this paper, and also agrees with the outcome of a Mat-lab simulation.

References

- 1 Habrouk M E, Darwish M K, Metha P. IEE Proceedings-Electric Power Applications, 2000, **147**(5): 403–413
- 2 Mallat S. IEEE Trans. on Pattern Anal. Machine Entell., 1989,

11: 674–693

- 3 ZHANG Xiang-Cheng, TENG Zhao-Sheng. The Application of Wavelet Theory in Power Harmonics Detecting, Instrument and Meter User, 2004, **11**(2): 1031–1036