

Cosmic Ray Test Station for BESIII RPC

LIU Qian^{1,2;1)} ZHANG Jia-Wen¹ CHEN Jin¹ LI Ru-Bai¹ ZHAO Jian-Bing¹
HAN Ji-Feng^{1,2} XIE Yu-Guang^{1,2} YAO Ning^{1,3} QI Na-Ding¹

1 (Institute of High Energy Physics, CAS, Beijing 100049, China)

2 (Graduate School of the Chinese Academy of Sciences, Beijing 100049, China)

3 (Zhengzhou University, Zhengzhou 450052, China)

Abstract The BESIII experiment uses about 1200m² of resistive plate chambers(RPCs), which will all be tested in a cosmic test station before installation. The test facility is made of 3 streamer-tube chambers with a track reconstruction resolution of 2—3mm. Trigger is also provided by the streamer-tube chambers covering an area of 4m². A total of 8 RPCs can be tested simultaneously.

Key words BESIII, resistive plate chamber(RPC), cosmic ray test station

1 Introduction

The resistive plate chamber (RPC) is a new type of detector first developed by R.Santonico in the early 80's^[1], and many experiments such as LHC^[2–5], Belle^[6], Babar^[7], Monolith^[8], Opera^[9], and BESIII^[2]^[10, 11] have chosen RPC as one of their sub-detectors. The BESIII muon detector uses “typical” RPC which is composed of two resistive bakelite plates (block resistivity: $10^{11}\Omega\text{cm} \leq \rho_v \leq 10^{12}\Omega\text{cm}$) separated by polycarbonate spacers, working in the streamer mode with the following gas mixture:

Argon: C₂H₂F₄:iso-C₄H₁₀ = 50:42:8

Two RPCs are assembled in an aluminum box as a superlayer with readout strips placed between them, as shown in Fig. 1. There are nine superlayers of RPCs in the barrel, and eight in the endcaps. Each layer can measure one of the two coordinates: for example, the odd layers of barrel for longitudinal- η and the even layers for transversal- ϕ . Totally more than 1,200m² RPCs will be used in BESIII covering the polar angle of $|\cos\theta| = 0.93$.

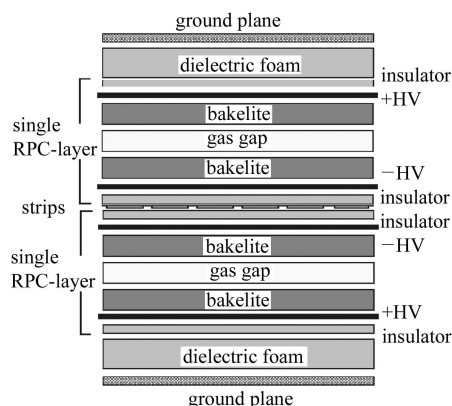

Fig. 1. A RPC superlayer module.

In order to control the production quality of RPCs, a cosmic-ray test station is built and all of RPCs will be tested before the installation in this dedicated cosmic ray test facility.

2 The cosmic ray test facility

The test station (Fig. 2) consists of a 4m long, 2.3m wide and 2m high support frame with seven layers. The tracking system is equipped with three (1st, 4th and 7th layer) streamer-tube chambers (1), the largest of which has a dimension of 2.6m×1.8m,

Received 2 September 2005, Revised 5 December 2005

1) E-mail: liujc@mail.ihep.ac.cn

2) BESIII Preliminary Design Report. IHEP-BEPCII-SB-13, 2004

and a total of eight RPCs (2) can be placed between them. Two scintillates (3) are installed to reduce shower events.

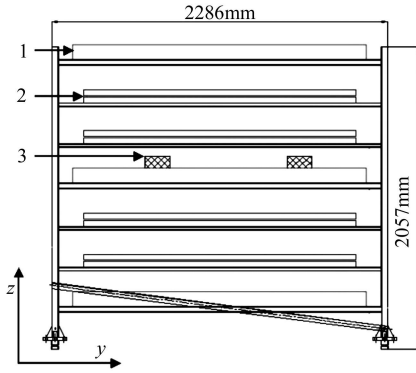

Fig. 2. Y view of the test station.

2.1 Streamer-tube chambers

The streamer-tube chamber is from the Aleph's muon detector^[12], which is an aluminum box in which streamer tubes are connected in series. The streamer tubes are made of plastic (PVC) comb-like wire tube with eight cells. Each cell has an inner dimension of $0.9\text{cm} \times 0.9\text{cm}$ and a wire of $100\mu\text{m}$ diameter, soldered on a HV distribution card, running along the length of the cell.

There are two layers of streamer tubes and four layers of readout strips in one streamer-tube chamber, two layers of readout strips are parallel to the wires (x -strips), 10mm pitch, which are set between the two layers of streamer tubes, the other two layers of readout strips are orthogonal to the wires (y -strips), 12mm pitch, which are set on the outside of the two layers of streamer tubes.

The streamer-tube chamber is applied a high voltage of 4.2kV, with a gas mixture of Ar:CO₂:isobutane = 23:47:30 and is working in the streamer mode.

The DAQ system of the streamer-tube chambers, as shown in Fig. 3, is composed of Front-End Cards (FECs), a Splitter Board, a convert board, and a CAMAC model-C187. FECs amplify and discriminate the signal induced by a streamer inside the tube and generate a digital "1" of $1\mu\text{s}$ if a 'Load' signal comes while the discriminator's output is high, the data are stored into one bit of a shift register chain which can be read out synchronized to the 'Clock' signal. The Splitter Board will generate and split the

control signals, such as Load, Test, Clock, the threshold level and the power, and obtain data from shift registers of FECs. The splitter board, designed for FASTBUS, is connected to the C187 module for data storage with the help of convert board. The C187 has eight independent synchronous cluster detection units, a FIFO memory ($512 \times 16\text{bits}$) for temporary data storage with "zero suppressing" mode.

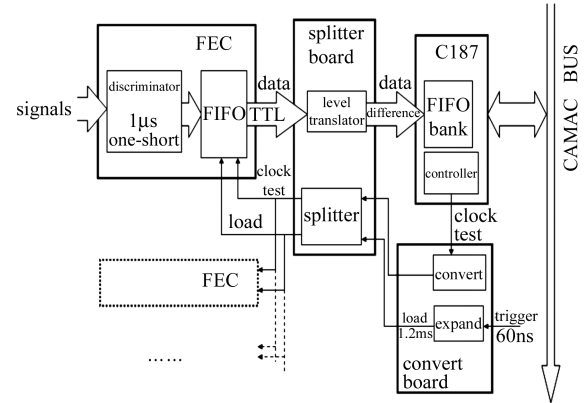

Fig. 3. Schematics of the DAQ system for the streamer-tube chambers.

2.2 Trigger

Since the streamer-tube chamber can give an "OR" signal for each layer of streamer tubes, the trigger system is made out by the three streamer-tube chambers in logic "AND", as shown in Fig. 4. In order to reduce events with electromagnetic showers, two scintillators are placed on the middle streamer tube, and their "AND" signal is used as a veto.

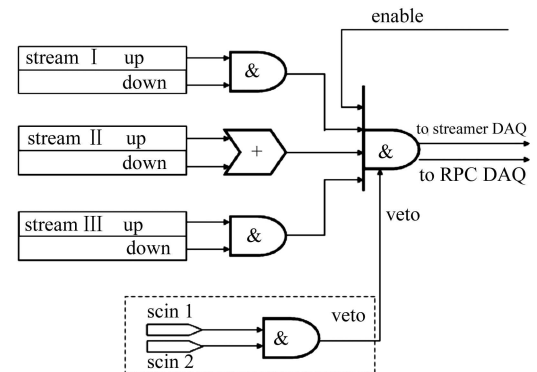

Fig. 4. The trigger and veto logic.

To eliminate the soft component of cosmic rays, a layer of 1cm thick lead shielding is placed between the middle and the bottom streamer-tube chambers. The trigger rate is about $8\text{Hz}/\text{m}^2$.

The trigger is sent to RPCs' and streamer-tube chambers' DAQ systems, and a timer set to ' ∞ ' will lock the trigger system until a reset signal generated after data acquisition is completed arrives.

2.3 DAQ

The data acquisition system for streamer-tube chambers is based on CAMAC crates, while that of RPCs' is based on an USB port. Data are stored separately and marked with unique event ID. They are then combined during data analysis.

The software of DAQ, control interface and graphic display are all based on ROOT package and the C++ language environment. An online event display and fast reconstruction are developed as shown in Fig. 5, a good event in Y view.

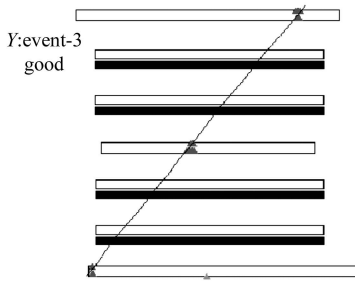

Fig. 5. Online event display of a cosmic-ray. (Y view, 8 RPCs are placed between streamer-tube chambers)

2.4 Reconstruction

Events are selected to fulfill the following requirements: The top and bottom streamer-tube chambers should have at least one good cluster, which is defined as no more than four conterminous strips fired, and the total number of good clusters of an event should be more than five and less than ten.

After the event selection, using the usual least squares method, a successful reconstruction should have a χ^2 probability greater than 0.1%. Otherwise the strip with the largest residual error will be removed and the event will be rejected if the total number of clusters is less than five after the removal. The track reconstruction resolution of streamer-tube chambers is 2–3mm.

If RPC's hit is present within a ± 1 RPC's strip width region near the projected point, the chamber is considered efficient.

2.5 Slow control, gas, and HV system

The environment parameters, such as temperature, humidity, are automatically measured and stored by a monitor LTM8901^[13] developed by BESIII slow control group. The gas mixing is controlled by MKS 1259B mass flow control system with a resolution of 0.1%. The high voltages are provided by a CAEN SY127 high voltage system, the currents of streamer-tube chambers and RPCs are recorded.

3 First test result

RPCs are read out by Cu strips with 35mm pitch through Front-End Cards (FECs) developed by USTC^[14, 15]. FECs are connected in series too. The FECs' output signal level is LVDS to reduce the power consumption. Data are collected by a mother board and read from USB. The main components on the FEC card are FPGA and the logic can be easily changed.

The efficiency distribution at 8kV is computed on a sample of an endcap chamber shown in Fig. 6. The shapes of tested chambers are a quarter of octagon, and the RPCs and streamer-tube chambers lie at an angle of 45 degree. The average efficiency excluding the edge of the RPC is about 98% at a threshold of 100mV. This test requires high statistic data samples (800,000 events corresponding to a track density of more than 20 tracks/plot, each plot is 35mm \times 35mm).

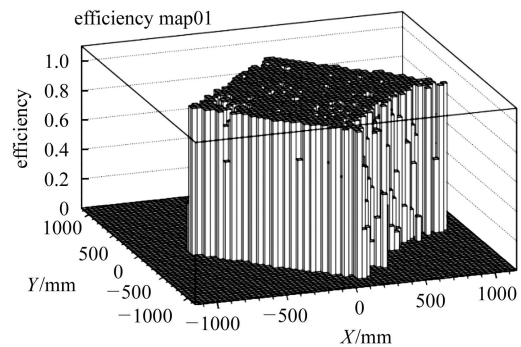

Fig. 6. Efficiency map of one of the tested RPC.

The spatial resolution of RPCs used in BESIII (Fig. 7) is determined from the residual distribution, after the correction for the intrinsic spatial resolution of

the streamer-tube chambers besides the track fitting error, it is about 13—16mm.

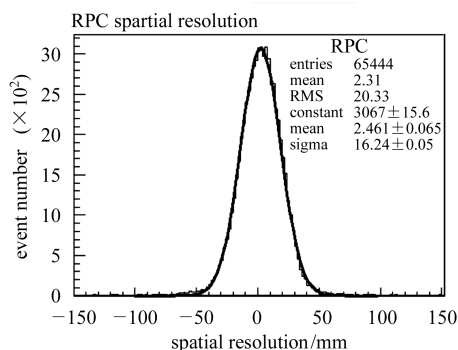

Fig. 7. Spatial resolution of RPC.

4 Conclusions

The cosmic ray test station has been put into operation since March 2005. Until now more than 27 RPC superlayers have been tested in the lab and most of them have a good stability and good performance over the period considered. By the cosmic test, some problematic RPCs were found and fixed immediately. The techniques of RPC assembly are thus improved and the cosmic ray test is proven to be effective.

We gratefully acknowledge XIE Yi-Gang, OUYANG Qun, Yang Yi for discussions and help.

References

- Santonico R. Nucl. Instrum. and Methods, 1981, **A 197**: 377
- ALICE Collaboration. Nucl. Instrum. and Methods, 2000, **A456**: 73—76
- ATLAS Muon Group. Nucl. Instrum. and Methods, 1996, **A384**: 222—224
- Fouz M C et al. Nucl. Instrum. and Methods, 2000, **A446**: 366—372
- Adinolfi M et al. Nucl. Instrum. and Methods, 2000, **A456**: 95—98
- Belle KLM Detecotr Group. Nucl. Instrum. and Methods, 2000, **A456**: 109—112
- Anulli F et al. Instrum. and Methods, 2003, **A515**: 322—327
- Ambrosio M et al. Instrum. and Methods, 2000, **A456**: 67—72
- Dusini S et al. Nucl. Instrum. and Methods, 2003, **A508**: 175—180
- ZHANG Jia-Wen et al. Nucl. Instrum. and Methods, 2005, **A540**: 102—112
- ZHANG Jia-Wen et al. HEP & NP, 2003, **27**(7): 615—618 (in Chinese)
(张家文等. 高能物理与核物理, 2003, **27**(7): 615—618)
- Iaselli G et al. The Hadron Calorimeter and Muon Detector. In: The Aleph Handbook. CERN, 1995. 35—64
- XIE Xiao-Xi et al. Nuclear Electronics & Detection Technology, 2005, **29**(5): 475 (in Chinese)
(谢小希等. 核电子学与探测技术, 2005, **29**(5): 475)
- CHEN Yi-Xin et al. Nuclear Techniques, to be published (in Chinese)
(陈一新等. 核技术, 待发表)
- XUE Jun-Dong et al. Nuclear Techniques, to be published (in Chinese)
(薛俊东等. 核技术, 待发表)

BESIII RPC 宇宙线测试系统

刘倩^{1,2;1)} 张家文¹ 陈进¹ 李如柏¹ 赵建兵¹ 韩纪峰^{1,2}
谢宇广^{1,2} 姚宁^{1,3} 漆纳丁¹

1 (中国科学院高能物理研究所 北京 100049)

2 (中国科学院研究生院 北京 100049)

3 (郑州大学 郑州 450052)

摘要 北京谱仪(BES III)采用阻性板室(Resistive Plate Chambers)作为其muon探测器,总使用面积达1200m². 为保证探测器的质量,每一块阻性板室都要求通过宇宙线测试. 宇宙线测试系统使用3个流光管室作为其触发和寻迹系统,其空间分辨可达2—3mm,覆盖面积约4m²,测试系统可同时测量8块RPCs. 最后,还报道了RPC的初次测试结果.

关键词 BES III RPC 宇宙线测试

2005-09-02 收稿, 2005-12-05 收修改稿

1) E-mail: liujc@mail.ihep.ac.cn